

On the Microstructure of High-Performance Polymer Materials



Brian R. Pauw^{a,b)}, Martin E. Vigild^{a)}, Kell Mortensen^{c)},
Jens W. Andreasen^{a,b)}, Enno A. Klop^{d)}

a) Danish Polymer Centre, Department of Chemical Engineering, NanoDTU
Technical University of Denmark, 2800 Kgs. Lyngby, Denmark

b) The Polymer Department, Risø National Laboratory, 4000 Roskilde, Denmark

c) Department of Natural Sciences, Faculty of Life Sciences,
University of Copenhagen, 1871 Frederiksberg C, Denmark

d) Teijin Twaron Research, Fiber Physics Group,
Teijin Twaron, 6800 TC Arnhem, The Netherlands



TEIJIN twaron

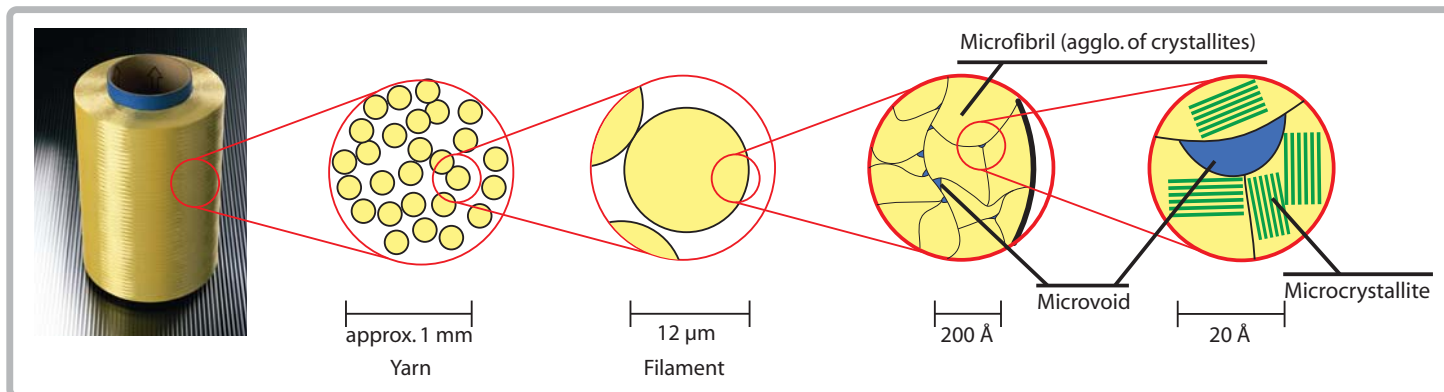

Figure 1: Microstructural elements of Twaron® at various levels of size. Leftmost image courtesy of Teijin Twaron.

Introduction

High-performance fibres such as Twaron® and Kevlar® have severely impacted the fibre market with their versatility and unparalleled performance since their appearance 30-odd years ago. Such fibres have also captured the interest of many researchers, and many aspects of the fibres have been investigated. However, whilst individual techniques have been applied to characterise the microstructure, no concatenation and comparison of these results has been published.

The Application of SAXS

Small-Angle X-ray Scattering (SAXS) will play a central role in these investigations. This technique excels for its lack of requirements for the sample and the validity of the data over the entire irradiated area.

SAXS has been extensively applied in the past to investigate the microfibrillar and micropore structure of many types of fibres. However, these techniques required many assumptions in order to simplify and linearise the data to make it suitable for parameter extraction. Thus, the methods developed in the past will benefit from revisions, to make them more suitable for the analysis of fibres. Simulations of scattering patterns will be used to verify the effect of the improvements on the analysis method.

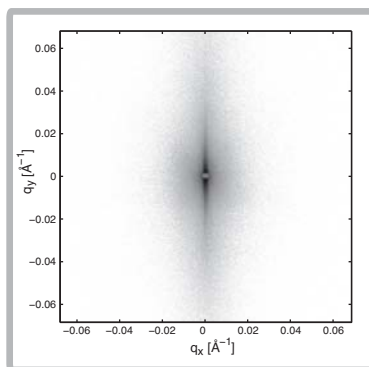

Figure 2: Twaron 1000 scattering pattern, showing a high degree of preferential orientation of the scatterers.

The Aim of the Project

The aim of this project is to provide an uncompromising and authoritative methodology to the determination of the microstructure of high-performance polymer materials. For this, many techniques (e.g. light scattering, (electron) microscopy and nitrogen absorption) will be applied, in order to verify, support and complement a complete view of the microstructure of such high-performance fibers.

The Equipment

At the Risø National Laboratories, a new custom built Small-angle X-ray camera has been commissioned (c.f. Figure 3). With this flexible set-up, a large range of sizes of the microstructural elements can be investigated. Regular measurements have been performed on 13 high-performance fibres with great success, which will be followed by measurements on an absolute intensity scale in the immediate future, in order to determine the volume fraction of scatterers. The large size of the sample chamber is ideal for mounting the sample heater and stretching set-up, which will provide further data on the influence of environmental changes on these fibres. A CCD camera, mounted on the sample chamber, provides additional wide-angle data on each of the samples, allowing characterisation of the crystalline elements in the fibres simultaneously with the nano-scale structural elements.

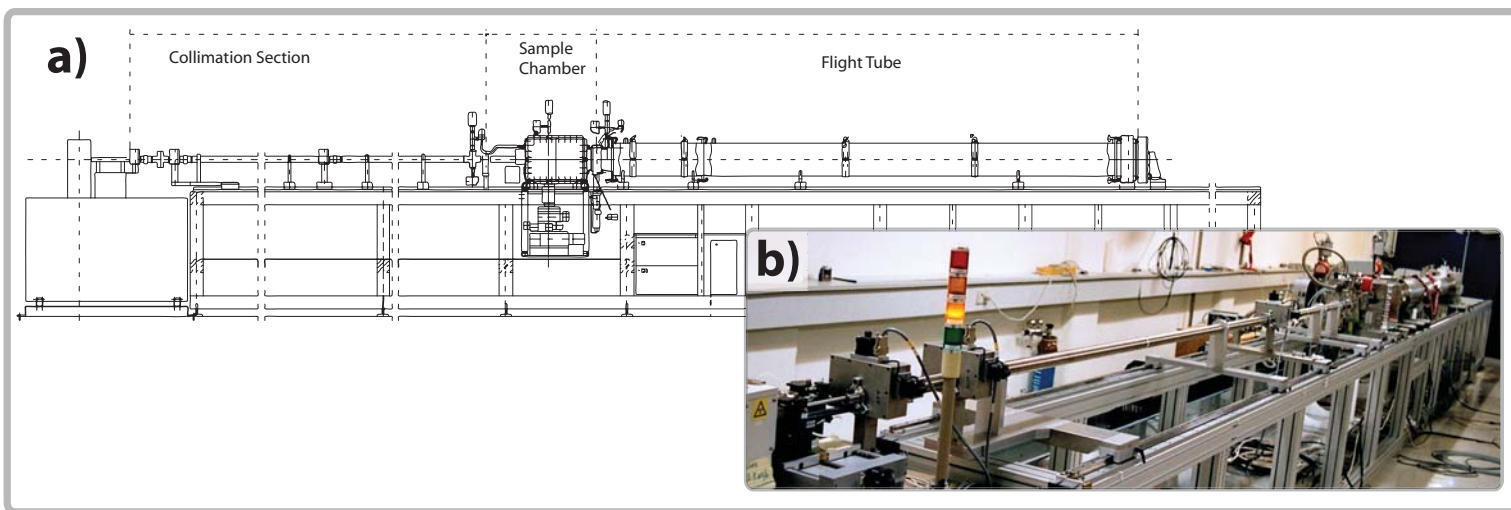

Figure 3: The Risø SAXS equipment schematically (a) and in real life (b)